

# Albeo™ LED Luminaire

Linear Lighting  
(ALR1 Series)

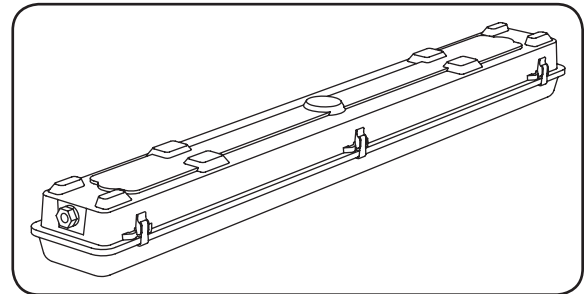

## BEFORE YOU BEGIN

Read these instructions completely and carefully.

### ⚠ WARNING/AVERTISSEMENT

#### RISK OF ELECTRIC SHOCK

- Turn power off before inspection, installation or removal.
- Properly ground electrical enclosure.

#### RISK OF FIRE

- Follow all NEC and local codes.
- Use only UL or IEC approved wire for input/output connections. Minimum size 18 AWG.

#### RISQUES DE DÉCHARGES ÉLECTRIQUES

- Coupez l'alimentation avant d'inspecter, installer ou déplacer le luminaire.
- Assurez-vous de correctement mettre à la terre le boîtier d'alimentation électrique.

#### RISQUES D'INCENDIE

- Respectez tous les codes NEC et codes locaux.
- N'utilisez que des fils approuvés par UL ou IEC pour les entrées/sorties de connexion. Taille minimum 18 AWG.

This device complies with Part 15 of the FCC Rules. Operation is subject to the following two conditions: (1) This device may not cause harmful interference, and (2) this device must accept any interference received, including interference that may cause undesired operation. CAN ICES-005 (A) / NMB-005 (A)

Note: This equipment has been tested and found to comply with the limits for a Class A digital device, pursuant to part 15 of the FCC Rules. These limits are designed to provide reasonable protection against harmful interference when the equipment is operated in a commercial environment. This equipment generates, uses, and can radiate radio frequency energy and, if not installed and used in accordance with the instruction manual, may cause harmful interference to radio communications. Operation of this equipment in a residential area is likely to cause harmful interference in which case the user will be required to correct the interference at his own expense.

## Save These Instructions

Use only in the manner intended by the manufacturer. If you have any questions, contact the manufacturer.

## Prepare Electrical Wiring



### Electrical Requirements

- The LED luminaire must be connected to the mains supply according to its ratings on the product label.



### Grounding Instructions

- The grounding and bonding of the overall system shall be done in accordance to local electric code of the country where the luminaire is installed.

## Tools and Components Required:

- ALR1 Series fixture
- Mounting hardware (not Included)
- #2 Phillips screwdriver
- Drill



imagination at work

## Components Included

- 1 Housing (1)
- 2 Lens (1)
- 3 Driver enclosure (1)
- 4 LED driver (2)
- 5 LED strip (1)
- 6 Housing latches (6)
- 7 Mounting brackets (2)
- 8 Endplug (1)

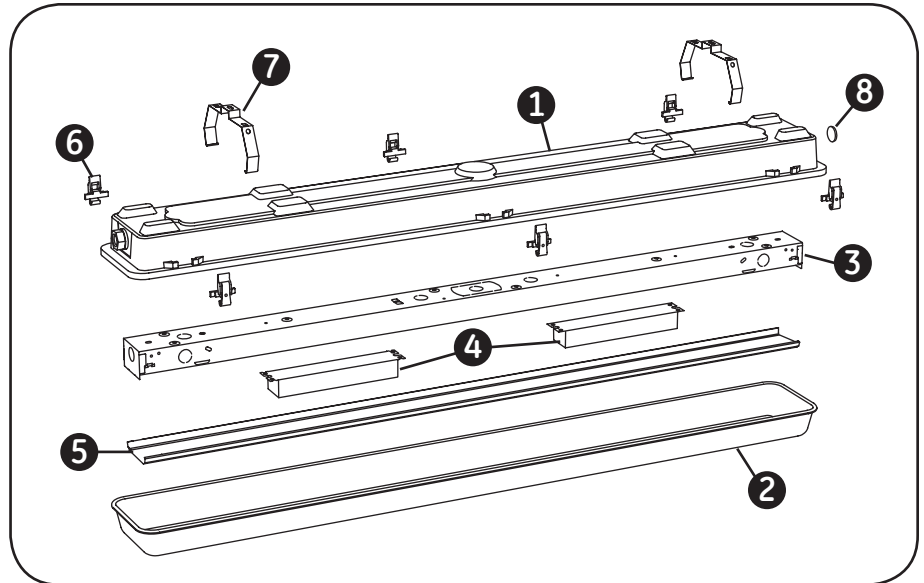

## Installation

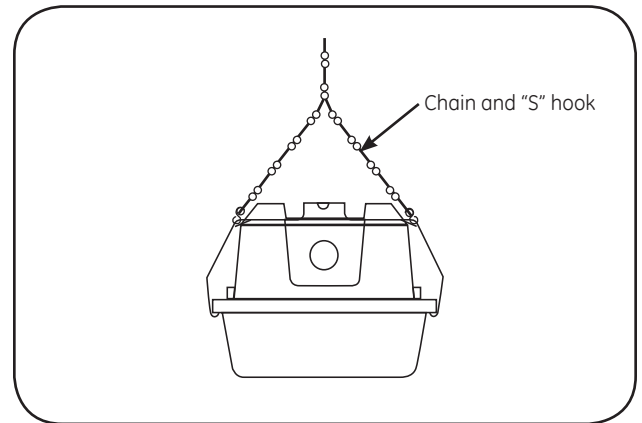
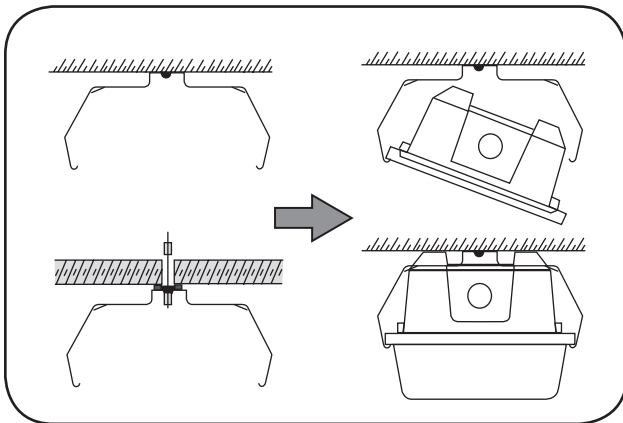

- 1 Mount the wrap-around brackets on the ceiling or support rail using appropriate hardware. After brackets are secured in place, install one side of the housing in the bracket, then rotate up and snap the other side of the housing into bracket. Chain and "S" hook (not included) can also be used to support the brackets

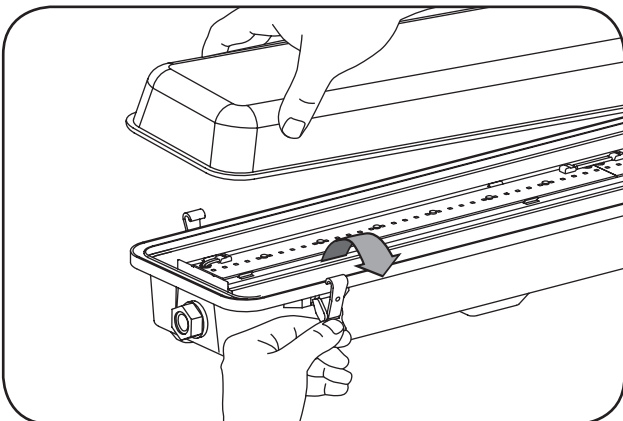

- 2 Unfasten the latches and remove the lens.

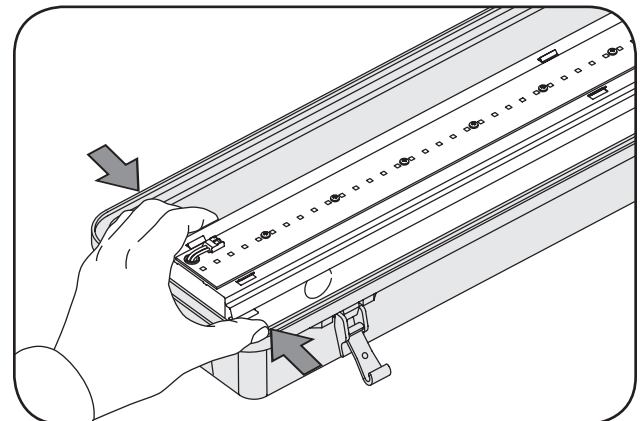

- 3 Squeeze the enclosure at the end and remove LED strip.

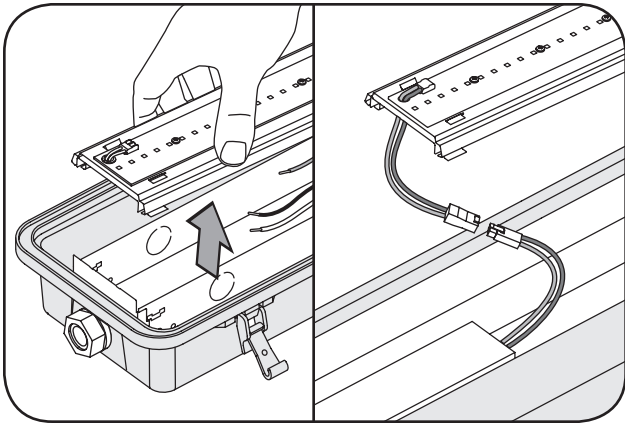

- 4** Lift LED strip from housing and disconnect from the LED driver.

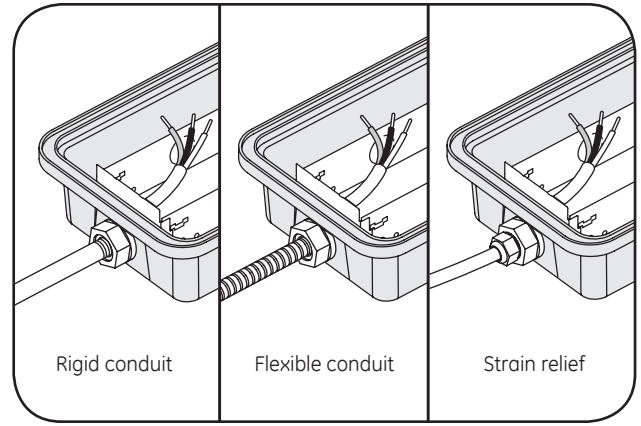

- 5** Connect a rigid conduit or flexible conduit or strain relief and feed the AC line wire through the fitting.

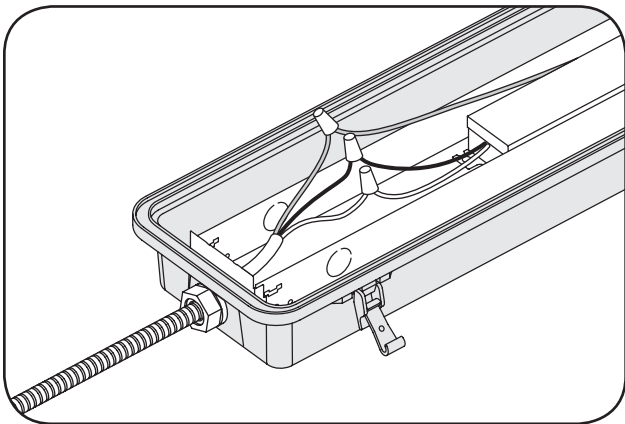

- 6** Connect the AC line to the black (line) and white (neutral) input wires of the LED driver using 14-18AWG twist-on wire connectors. Connect the ground wire to the green grounding wire.

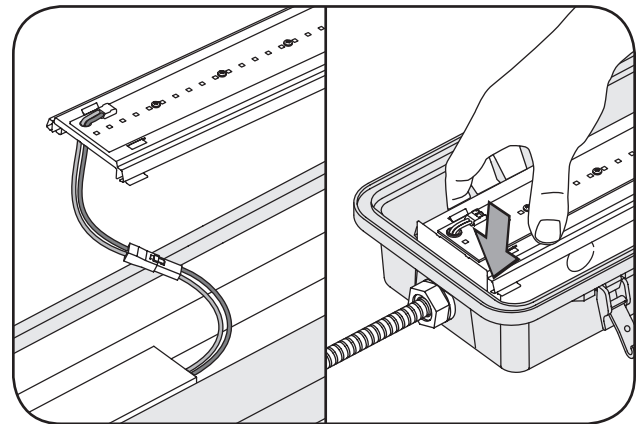

- 7** Reconnect similarly-colored wires from LED driver to LED strip. Then reattach the LED strip making sure the two end clips are properly engaged.

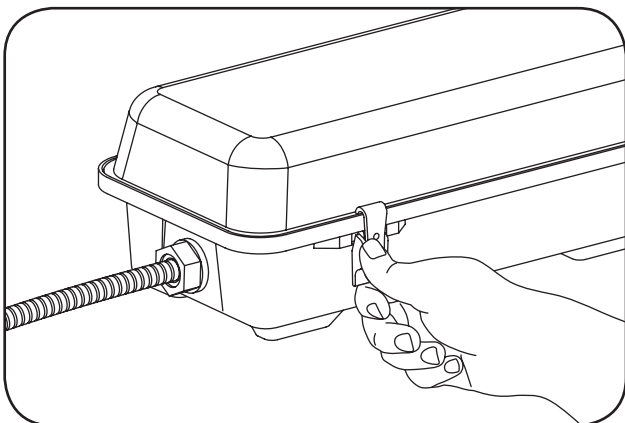

- 8** Reinstall the lens and secure the latches.

# Wiring Diagram

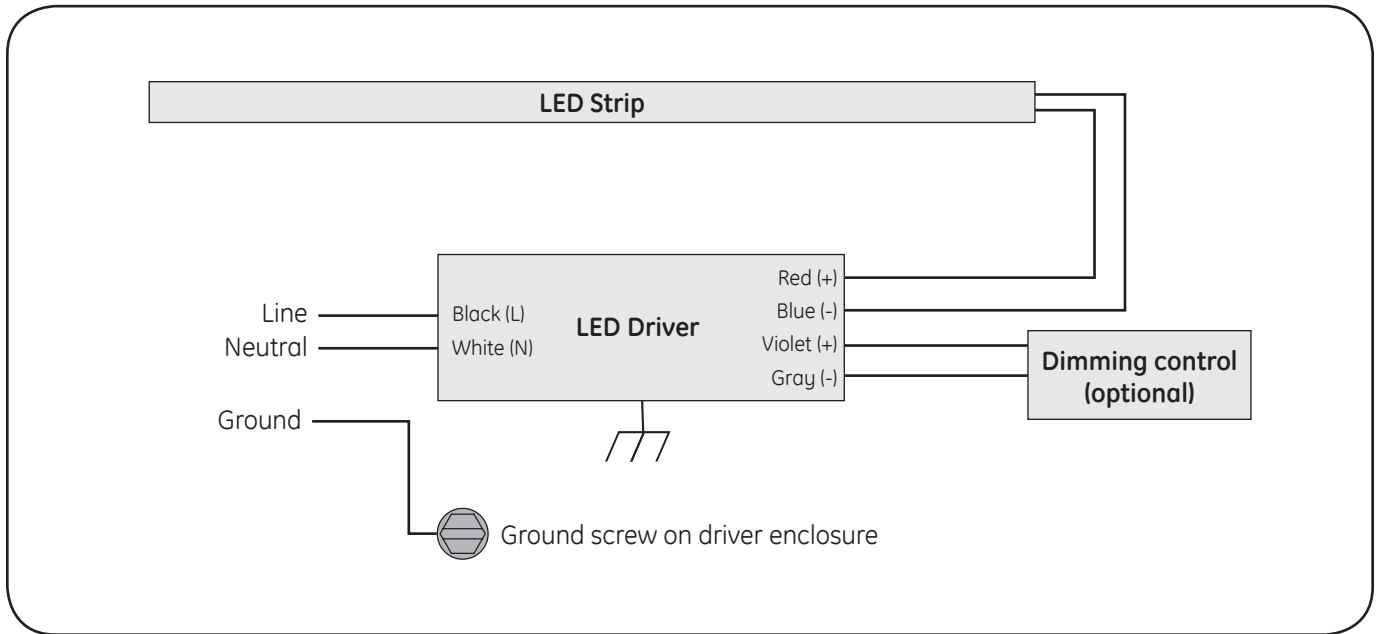

[www.gelighting.com](http://www.gelighting.com)

GE and the GE Monogram are trademarks of the General Electric Company. All other trademarks are the property of their respective owners. Information provided is subject to change without notice. All values are design or typical values when measured under laboratory conditions. GE Lighting is a business of the General Electric Company. © 2017 GE.

ALB022 (Rev 09/07/17)