

Lumination™ LED Luminaires

(For LET Series)



BEFORE YOU BEGIN

Read these instructions completely and carefully.

⚠ WARNING/AVERTISSEMENT

RISK OF ELECTRIC SHOCK

- Turn power off before inspection, installation or removal.
- Properly ground electrical enclosure.

RISK OF FIRE

- Follow all NEC and local codes.
- Use only UL or IEC approved wire for input/output connections. Minimum size 18 AWG (0.75mm²).
- Do not install insulation within 3 inches (76 mm) of luminaire top.

RISQUES DE DÉCHARGES ÉLECTRIQUES

- Coupez l'alimentation avant d'inspecter, installer ou déplacer le luminaire.
- Assurez-vous de correctement mettre à la terre le boîtier d'alimentation électrique.

RISQUES D'INCENDIE

- Respectez tous les codes NEC et codes locaux.
- N'utilisez que des fils approuvés par UL ou IEC pour les entrées/sorties de connexion. Taille minimum 18 AWG (0.75mm²).
- Maintenir une distance de 76 mm (3 pouces) entre le luminaire et l'isolant.

Save These Instructions

Use only in the manner intended by the manufacturer. If you have any questions, contact the manufacturer.

Prepare Electrical Wiring



Electrical Requirements

- The LED luminaire must be connected to the mains supply according to its ratings on the product label.



Grounding Instructions

- The grounding and bonding of the overall system shall be done in accordance to local electric code of the country where the luminaire is installed.

⚠ CAUTION /ATTENTION!

Do not perforate the integrity of the luminaire. Only screw into the threaded mounting bracket holes located at the four corners of the fixture. /
Ne pas perforez l'intégrité du luminaire. N'utilisez que les vis fournies pour l'installation des supports de fixation. N'utilisez que les trous filetés situés aux quatre coins de l'appareil.

Luminaire Installation

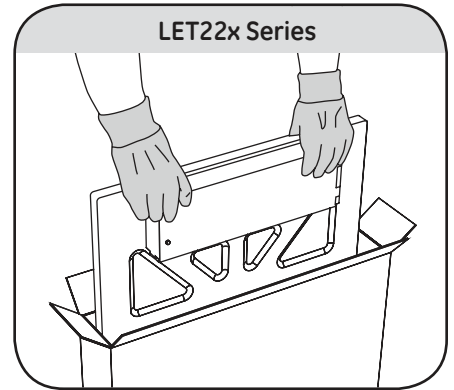
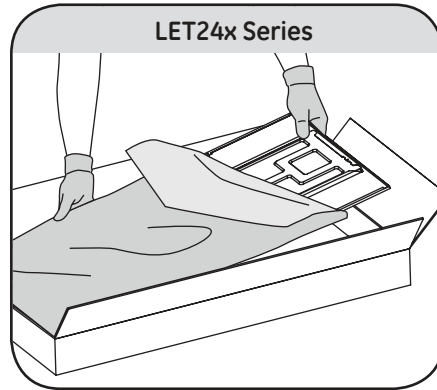
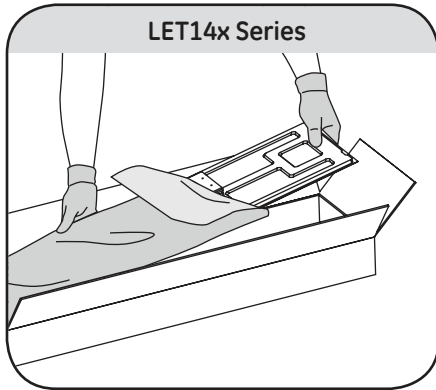

- 1 Carefully unpack unit from its packaging. Properly inspect for defects before installing. Wear work gloves to prevent dirt and oil from being transferred to the luminaire.

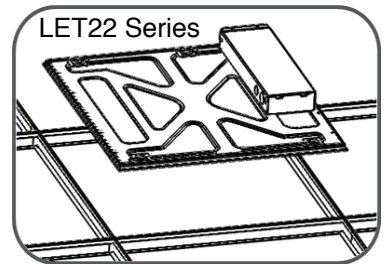
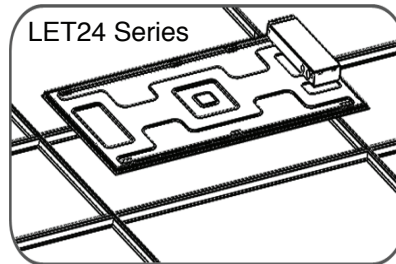
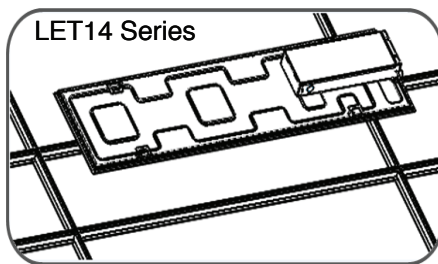

- 2 Insert luminaire into T-bar ceiling grid. Unit should not move freely within the ceiling grid. To ensure a consistent appearance, align fixtures in the same orientation throughout the ceiling pattern.

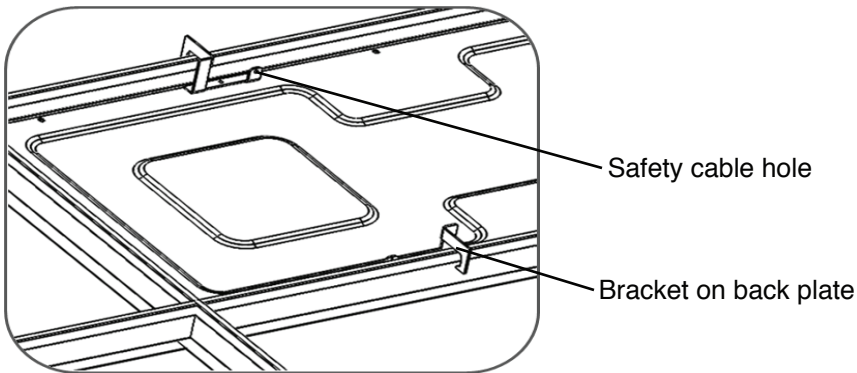

- 3 Bend the brackets on the back plate to make sure they hook to T-Bar.

Secure safety cable to connection hole as needed to meet local seismic requirements. Safety cable and method of attachment to the building are provided by contractor according to local building codes.

Electrical Connections

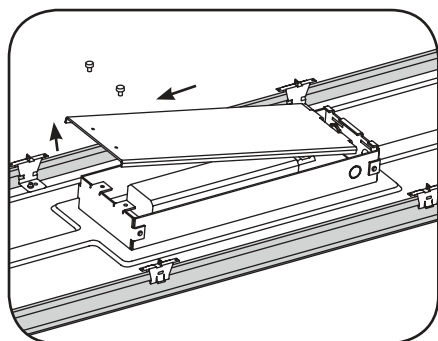

1 Remove electrical enclosure cover. Carefully remove knockout for AC line input wires. Install listed electrical fittings in the knockout holes for wire protection.

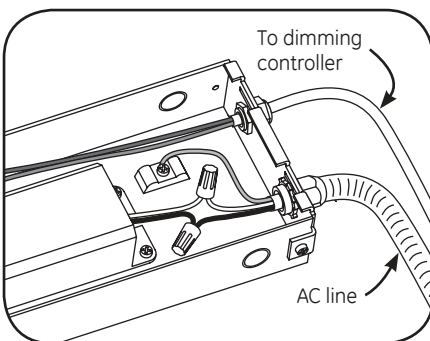

2 Connect the AC line to the black (line) and white (neutral) input wires of the LED driver using 18-14 AWG twist-on wire connectors. Connect the ground wire to the green grounding screw. When connecting dimming controller, wires must run through a separate knockout hole equipped with an appropriate wire restraint or cable gland.

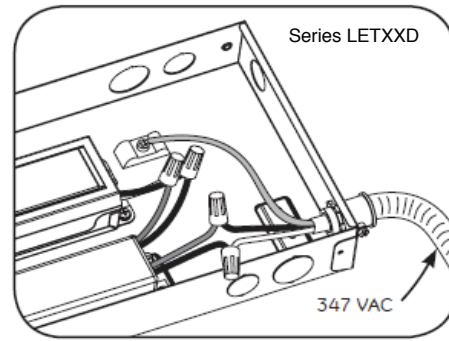

For Series LETXXD, be sure to connect the 347VAC line to the black (line) and white (neutral) input wires of the transformer

Optional Installation: 0-10V Volt Dimming

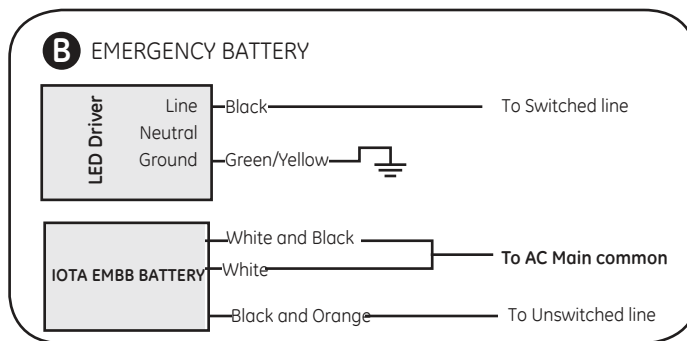
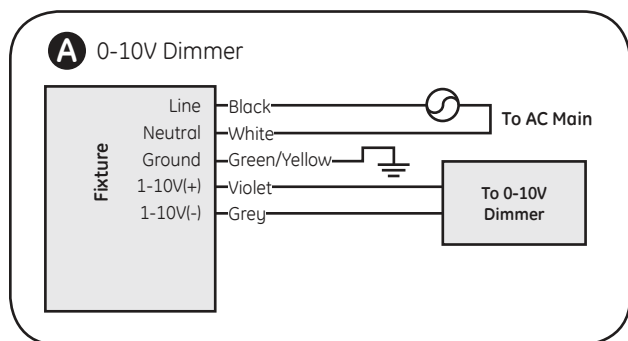

3 *Option for Step 2:* Follow diagram A for 0-10V or diagram B for EMBB. Run wires from controller through a different knockout than the AC input wire. At output side of fixture, make appropriate connections using twist-on wire connectors. Follow lighting controller and IOTA EMBB installation instructions.

This device complies with Part 15 of the FCC Rules. Operation is subject to the following two conditions: (1) This device may not cause harmful interference, and (2) this device must accept any interference received, including interference that may cause undesired operation. CAN ICES-005 (A) / NMB-005 (A)

Note: This equipment has been tested and found to comply with the limits for a Class A digital device, pursuant to part 15 of the FCC Rules. These limits are designed to provide reasonable protection against harmful interference when the equipment is operated in a commercial environment. This equipment generates, uses, and can radiate radio frequency energy and, if not installed and used in accordance with the instruction manual, may cause harmful interference to radio communications. Operation of this equipment in a residential area is likely to cause harmful interference in which case the user will be required to correct the interference at his own expense.



www.currentbyge.com, www.gelighting.com

All trademarks are the property of their respective owners. Information provided is subject to change without notice. All values are design or typical values when measured under laboratory conditions. Current, powered by GE is a business of the General Electric Company.

© 2017

IND409 (Rev 06/22/17)