



Lumination™ Controls Accessory

LPL Series Controller Box



BEFORE YOU BEGIN

Read these instructions completely and carefully.

⚠ WARNING/AVERTISSEMENT

RISK OF FIRE OR ELECTRIC SHOCK

- Turn power off before inspection, installation or removal.
- Properly ground electrical enclosure.
- Follow all NEC and local codes.
- Do not make or alter any open holes in an enclosure of wiring or electrical components during kit installation.
- Fixture may fall down if not installed properly, follow installation instructions.
- Wear safety glasses and proper aid during installation and maintenance.
- Install this kit only in the luminaires that has the construction features and dimensions shown in the photographs and/or drawings.
- Above ceiling access required.
- LED Retrofit Kit installation requires knowledge of luminaires electrical systems. If not qualified, do not attempt installation. Contact a qualified electrician.

RISQUES D'INCENDIE OU DE DÉCHARGES ÉLECTRIQUES

- Coupez l'alimentation avant d'inspecter, installer ou déplacer le luminaire.
- Assurez-vous de correctement mettre à la terre le boîtier d'alimentation électrique.
- Respectez tous les codes NEC et codes locaux
- Ne pas percer ou altérer les tr électrique durant l'installation.
- Le luminaire peut tomber s'il nest pas installé correctement, suivre les instructions d'installation
- Porter des lunettes de sécurité et les aides appropriées lors de l'installation et de l'entretien.
- Installez ce kit uniquement dans les appareils d'éclairage qui a les caractéristiques de la construction et les dimensions indiquées dans les photographies et/ou dessins.
- Accès requis au-dessus du plafond.
- L'installation du kit nécessite la connaissance des systèmes électriques des luminaires. Si vous n'êtes pas qualifié, ne tentez pas l'installation. Contactez un électricien qualifié.

Prepare Electrical Wiring



Electrical Requirements

The LPL Controller Box must be supplied with 120V/277V, 50/60Hz or 347V, 50/60Hz for LXAMBAXXXXXXX and is intended only for LPL Series Fixtures.



Grounding Instructions

The grounding and bonding of the overall system shall be done in accordance to local electric code of the country where the luminaire is installed.

Save These Instructions

Use only in the manner intended by the manufacturer. If you have any questions, contact the manufacturer.

Tools and Components Required

- Screwdriver
- UL Listed conduit connections per NEC/CEC for nominal conduit trade size ½" or ¾"
- UL Listed wire connectors

Specifications

Description Code for Control Units

TS - Daintree Wireless Fixture Adapter (120-277 VAC)

TQ - LG Innotek Wireless Interface Module (120-277 VAC)

T1 - Daintree One (120-277VAC)

TT - Daintree EZ Connect (120-277VAC)

TZ - Daintree Enterprise (120-277VAC)

SQ - Daintree Sensor Ready (120-277VAC)

Installation

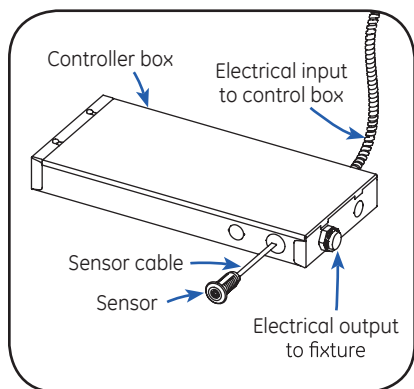

Part identification

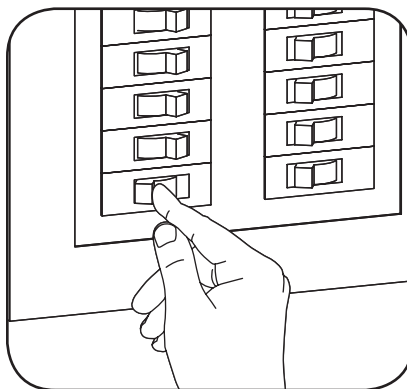

1 Disconnect incoming power to the fixture at the panel.

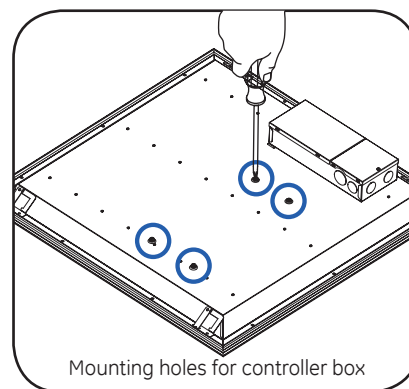

Mounting holes for controller box

2 Remove screws at the back of luminaire. Keep the screws for later use.

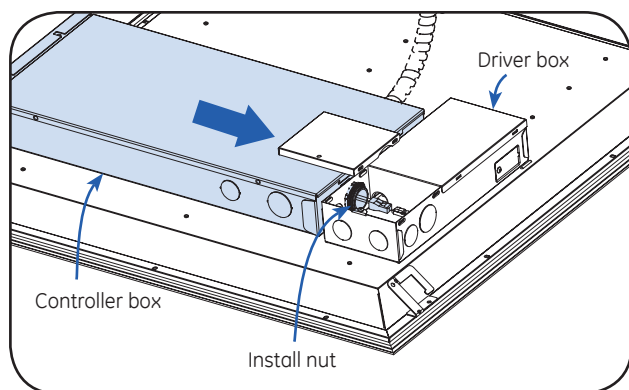

3 Insert the conduit fitting to the driver box and screw the nut to connect them. Make sure all the electrical wires are inserted together into the driver box and connect the wires according to the appropriate wiring diagram on pages 3-4.

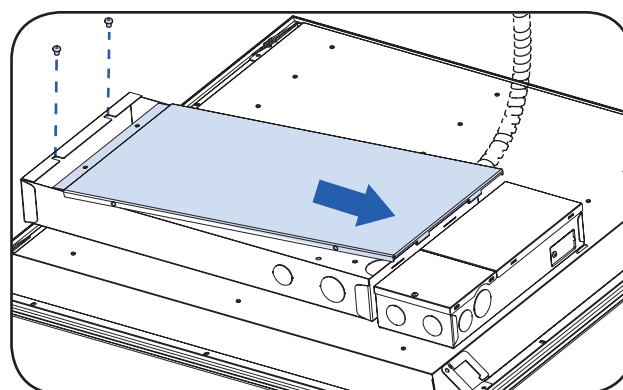

4 Remove the screws and open the control box cover by sliding it aside.
NOTE: Keep the screws and star washers for later use.

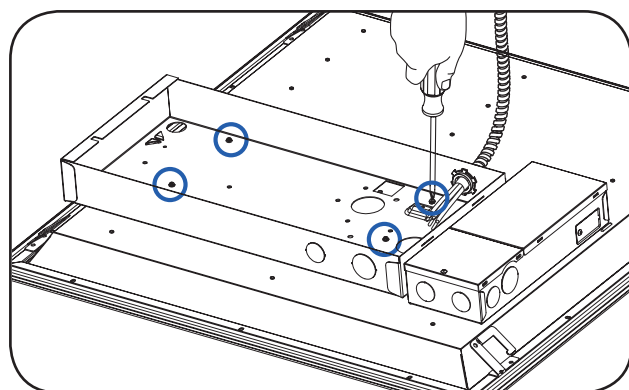

5 Fix the controller box to the back of the luminaire using the four available holes and the screws from Step 2.

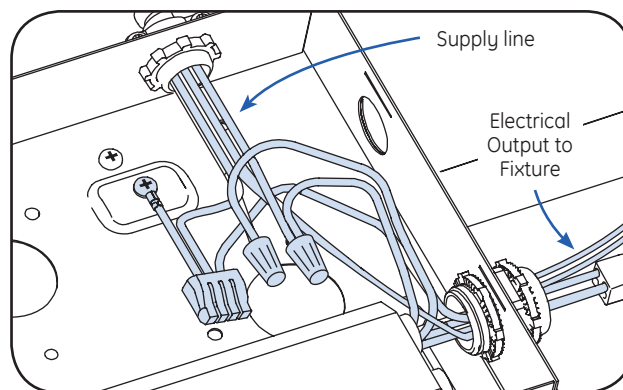

6 Make supply line connections inside the controller box assembly. Refer to the appropriate wiring diagram on pages 3-4 to identify proper connections. Replace the cover using the screws and star washers.

- 7 Position and install sensor in the ceiling using provided hardware.
- 8 Optional: Turn on fixture and perform Light Up Self-Test. (Only for Enlighted sensor version)

Wiring Diagrams

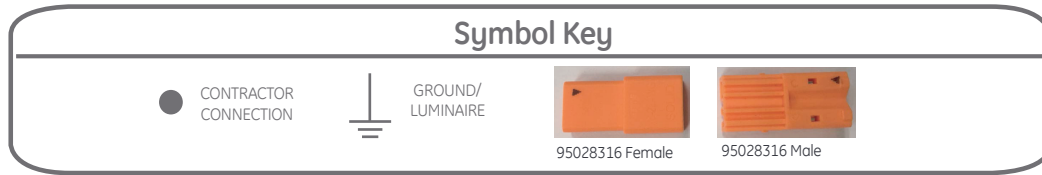

1-10V Dimming: 347V Version

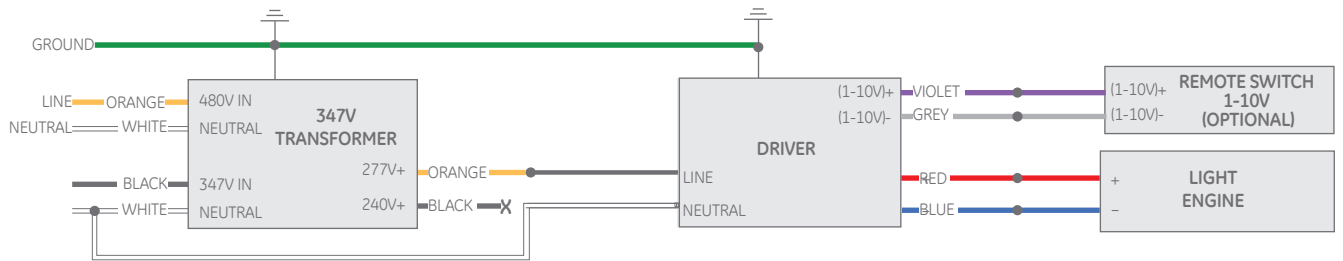

1-10V Dimming: EMBB Version

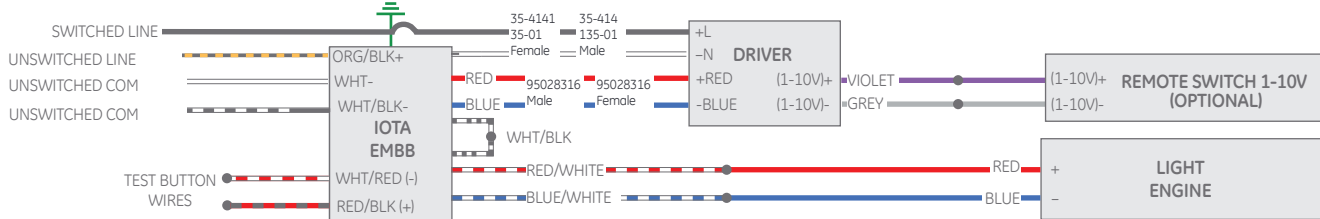

Emergency Bypass with Controls

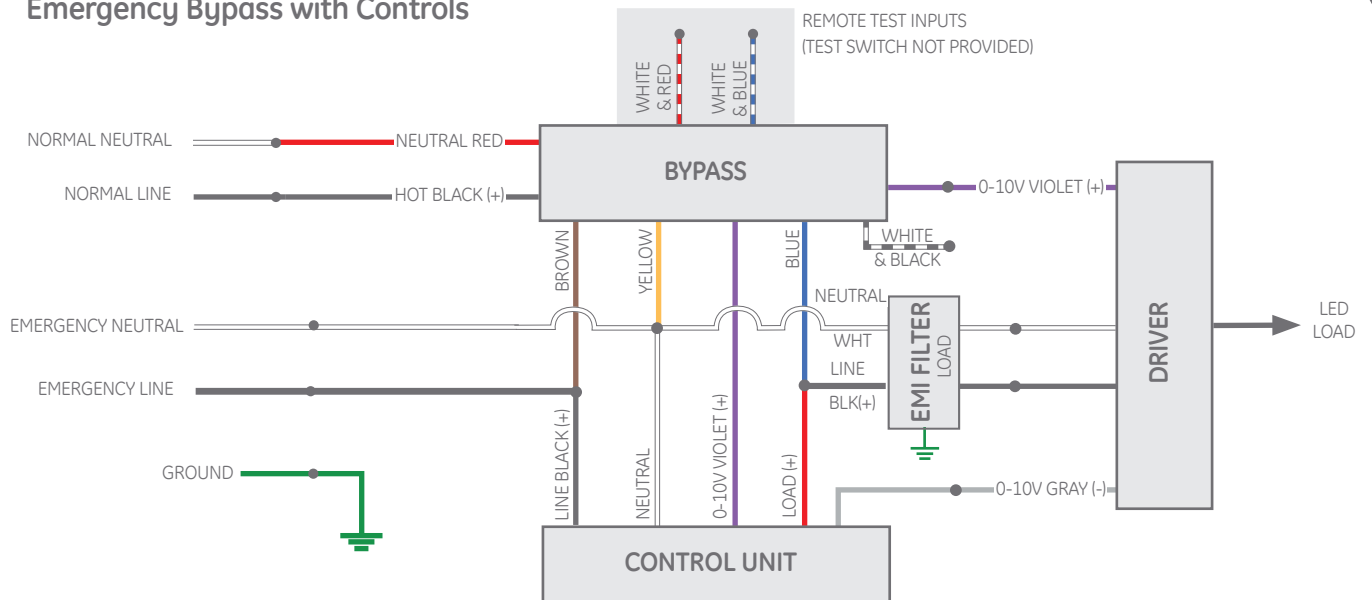

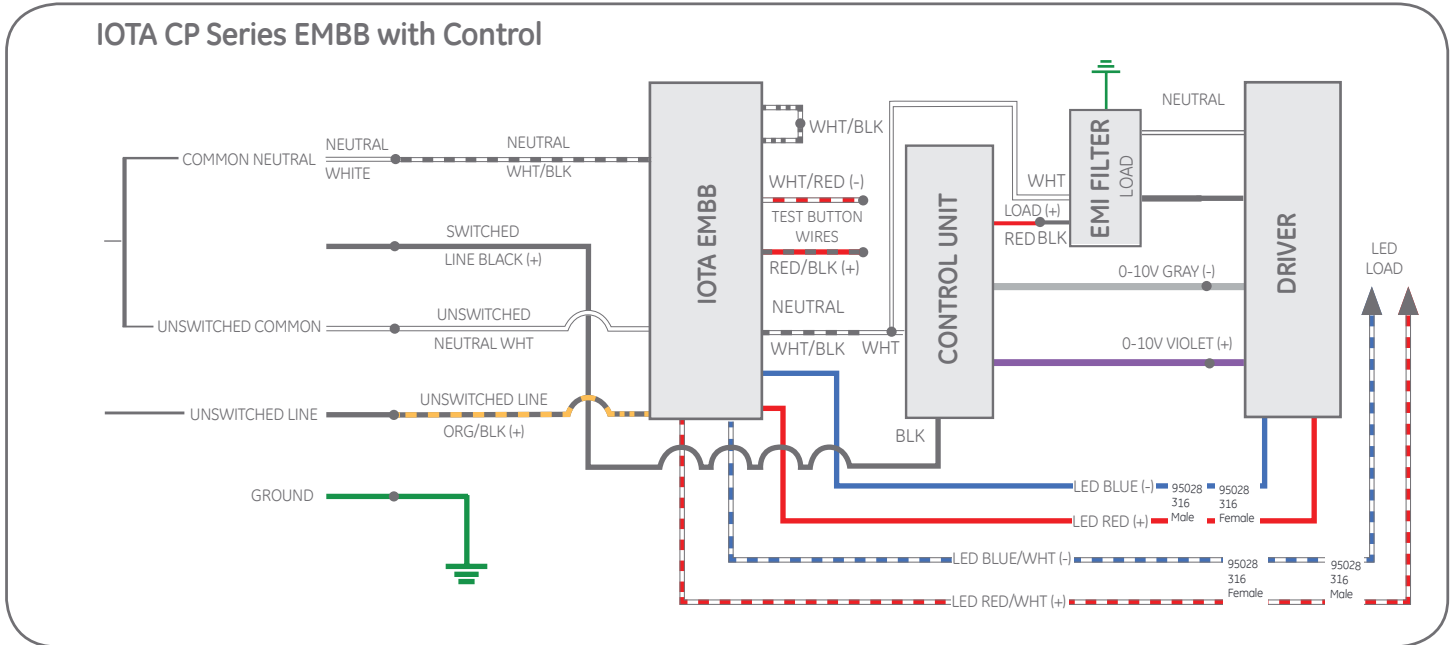
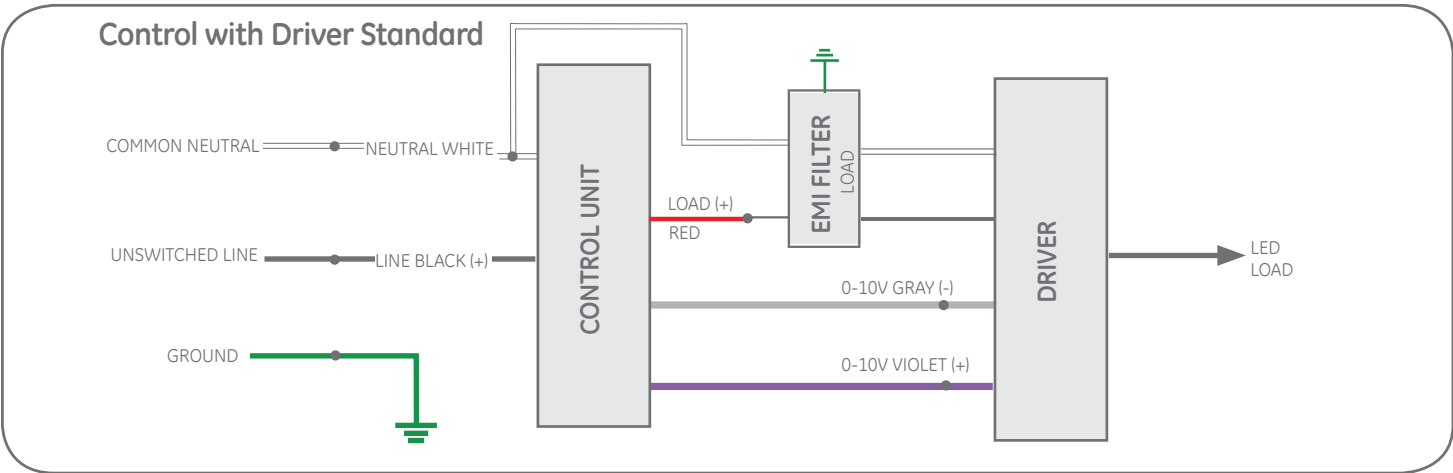

- NOTE:** ① For further information refer to EMBB installation instructions by searching for proper model number at www.iotaengineering.com
- ② If the connector provided in the controls kit is not compatible with the connector in the wiring compartment, replace the controls kit connector with the additional Wago connector (Yellow) provided separately in the controls kit package.

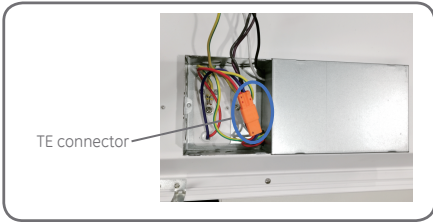

Control Identification and Start Up

Daintree Controller

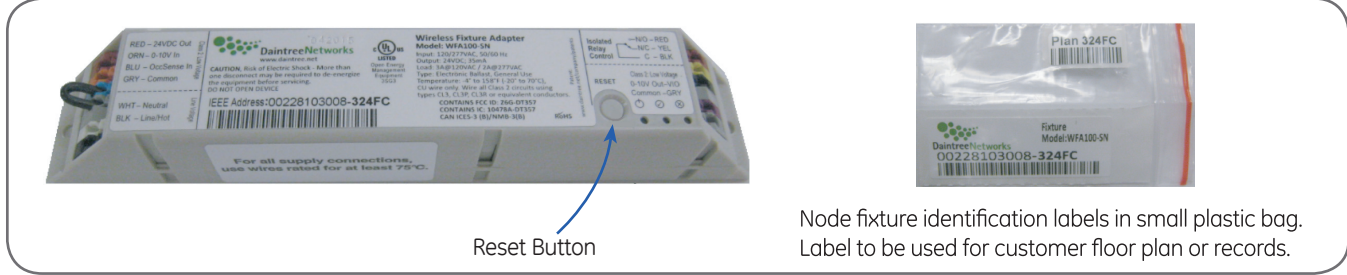

LABELS: The labels are in a small plastic bag and can be visible either on the control unit itself or near the fixture labels on the outside of the luminaire. These labels can be left in the same visible spot, or they can be placed in an area that is easy to access for easy identification.

LG Controller (Compatible with Daintree)

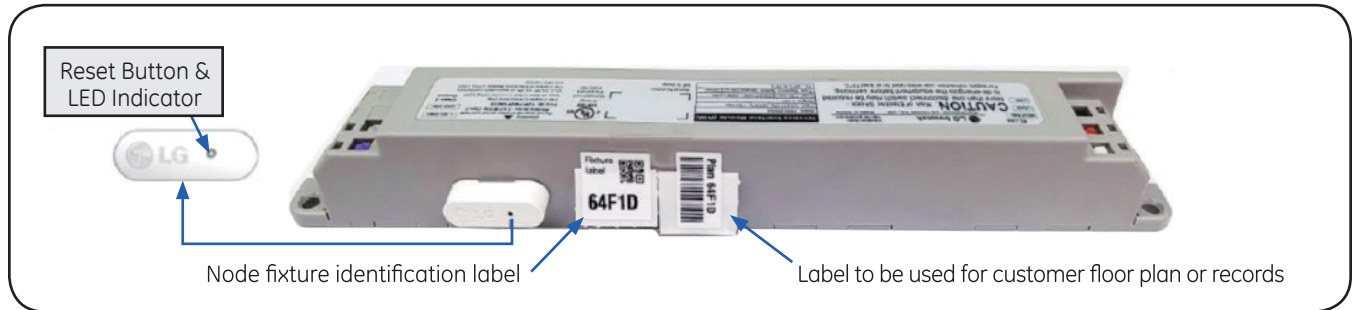

LABELS: The labels can be visible either on the control unit itself or near the fixture labels on the outside of the luminaire. These labels can be left in the same visible spot, or they can be placed in an area that is easy to access for easy identification.

Interface Module (SQ)



EMERGENCY BYPASS OPTION: Connect the BLACK and RED wires from the fixture to the normal, non-emergency AC wires to detect whether or not the fixture is in emergency mode.

NOTES:

- See diagram to right for wire colors and descriptions.
- Self-Test Input must be from same branch circuit as normal neutral and normal hot.
- Remote test switch is not provided.
- Remote test input is performed when input is CLOSED.

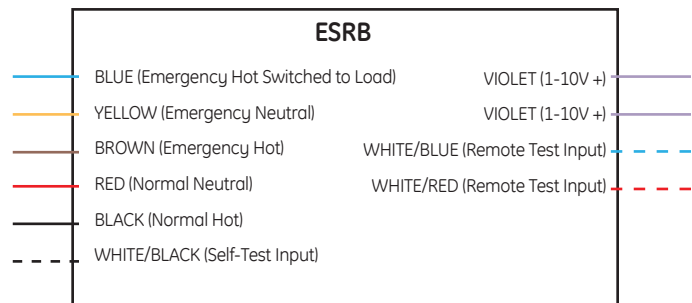

* For further information on the bypass unit, refer to www.functionaldevices.com

This device complies with Part 15 of the FCC Rules. Operation is subject to the following two conditions: (1) This device may not cause harmful interference, and (2) this device must accept any interference received, including interference that may cause undesired operation. CAN ICES-005 (A) / NMB-005 (A)

Class A Note: This equipment has been tested and found to comply with the limits for a Class A digital device, pursuant to part 15 of the FCC Rules. These limits are designed to provide reasonable protection against harmful interference when the equipment is operated in a commercial environment. This equipment generates, uses, and can radiate radio frequency energy and, if not installed and used in accordance with the instruction manual, may cause harmful interference to radio communications. Operation of this equipment in a residential area is likely to cause harmful interference in which case the user will be required to correct the interference at his own expense.

Intentional Radiator Note: This device complies with part 15 of the FCC rules for the United States and Industry Canada (IC) license exempt RSS standard(s). Operation is subject to the following two conditions: (1) This device may not cause harmful interference, and (2) this device must accept any interference received, including interference that may cause undesired operation. Any changes or modifications not expressly approved by the manufacturer could void the user's authority to operate this equipment. This product is intended for commercial use only.